

Features

- High flow in a compact design.
- High pressure capacity designed for blow-out proof with internally loaded ball stem.
- Micro-finished ball provides a positive seal.
- 90 degree actuation for 2-way and 180 degree actuation for 3-way ball valves.
- Panel mounting as standard.
- Chevron stem seal, adjustable with the handle disassembled.
- Handle indicates flow direction.
- Low operating torques and positive handle stops.
- Optional pneumatic actuation.

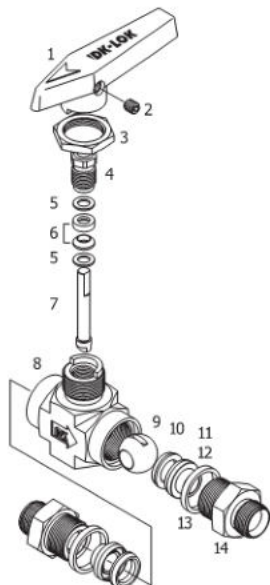

Material of Construction

Components	Valve Body Material Stainless Steel Grade/ASTM Specification
1. Handle	Nylon with brass insert
2. Set Screw	Stainless steel
3. Panel Nut	
4. Packing bolt*	SS316/A276
5. Upper / Lower Gland	
6. Stem Chevron Packing	PTFE/D1710 type 1, Grade 1, Class B
7. Stem	SS316/A276
8. Body	SS316/A182 Type F316
9. Ball	SS316/A276
10. Seat (2)	Standard PCTFE (Kel-F), optional PTFE, PEEK
11. Retainer (2)	SS316/A276
12. Retainer Seal (2)	
13. End Connector Seal (2)	PTFE/D1710 type 1, Grade 1, Class B
14. End Connector (2)	SS316/A276

- * Molybdenum disulfide with hydrocarbon coating
- Wetted parts and lubricants are listed in blue.
 - Lubricant is Fluorinated-based.

Operation and Packing Adjustment

- VH86 valves are designed to control fluid in full open and closed position, using VH86 valves to throttle the flow may reduce the valve life.
- Stem packing can be adjustable with the handle disassembled. Tighten packing bolt clockwise to tighten the stem packing.
- Valves that have not been actuated for a period of time may have a higher initial actuation torque.
- If the valve system needs to be tested at higher pressure than the valve maximum pressure, the valve must be in open position during the test so as not to damage the valve seat.
- Optional Sour Gas Service applicable.

Application

VH86 series ball valve offers a safe and reliable performance in a wide range of onshore and offshore applications: Water, oil, gas, petrochemical in heavy duty applications.

Factory Test, Cleaning and Packaging

- Every valve is factory tested with nitrogen gas at 1,000 psig (68.9 bar) for leakage at seat to a maximum allowable leak rate of 0.1 SCCM. The packing is tested with nitrogen gas for no detectable leakage.
- Every valve is cleaned and packaged in accordance with DK cleaning standard DC-01.

Bi-directional 2-way Ball Valves

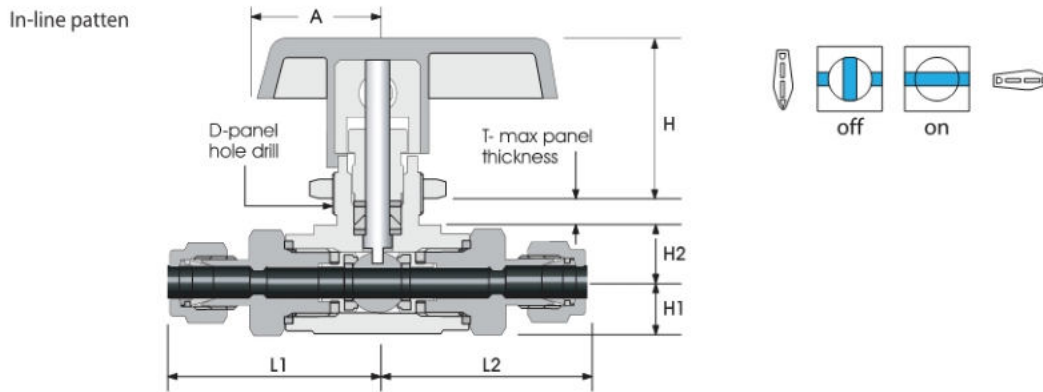

Technical Data

Valve Series	Sealing Materials			Pressure Rating @-27 to 37 °C (-20 to 100 °F)	Temperature Rating
	Seat	Stem Packing	Retainer / End Seal		
VH86A, VH86B, and VH86C series	PCTFE	PTFE	PTFE	6,000 psig (413 bar)	-30 to 180 °C (-22 to 356 °F)
	PEEK	PTFE	PTFE	6,000 psig (413 bar)	-54 to 230 °C (-65 to 446 °F)
	PTFE	PTFE	PTFE	1,500 psig (103 bar)	-30 to 176 °C (-22 to 349 °F)

• PCTFE is standard seat material.

Ordering Information and Dimensions

Basic Ordering Number	End Connections		Orifice		Cv	Dimensions mm (in.)							
	Inlet	Outlet	mm	inch		L1	L2	H1	H2	H	A	D	T
VH86A-	D-1T- 1/16" DK-Lok		1.3	0.052	0.06	33.0(1.30)	33.0(1.30)	9.5 (0.37)	8.5 (0.33)	24.8 (0.98)	19.1 (0.75)	14.7 (0.58)	3.3 (0.13)
	D-2T- 1/8" DK-Lok		2.4	0.0945	0.21	34.5(1.36)	34.5(1.36)						
	F-2N- 1/8" Female NPT		4.2	0.165	0.43	27.2(1.07)	27.2(1.07)						
	M-2N- 1/8" Male NPT		4.2	0.165	0.43	30.0(1.18)	30.0(1.18)						
	D-4T- 1/4" DK-Lok		4.2	0.165	0.43	37.6(1.48)	37.6(1.48)						
	M-4N- 1/4" Male NPT		4.2	0.165	0.43	34.3(1.35)	34.3(1.35)						
	D-3M- 3mm DK-Lok		2.2	0.086	0.18	34.8(1.37)	34.8(1.37)						
	D-2T- 1/8" DK-Lok		2.4	0.0945	0.26	41.9(1.65)	41.9(1.65)						
VH86B-	D-4T- 1/4" DK-Lok		4.7	0.185	1.04	44.2(1.74)	41.1(1.62)	10.7 (0.42)	11.9 (0.47)	38.9 (1.53)	25.4 (1.00)	19.6 (0.77)	6.4 (0.25)
	MD-4N4T- 1/4" Male NPT 1/4" DK-Lok												
	FD-4F4T- 1/4" Female NPT 1/4" DK-Lok												
	F-4N- 1/4" Female NPT												
	M-4N- 1/4" Male NPT												
	MF-4N- 1/4" Male NPT 1/4" Female NPT												
	MD-4N6T- 1/4" Male NPT 3/8" DK-Lok												
	FD-4N6T- 1/4" Female NPT 3/8" DK-Lok												
	D-6T- 3/8" DK-Lok												
	M-6N- 3/8" Male NPT												
	D-6M- 6 mm DK-Lok												
	D-8M- 8 mm DK-Lok												
VH86C-	D-10M- 10 mm DK-Lok		6.4	0.252	2.34	92.0(3.62)	99.0(3.90)	17.5 (0.69)	17.8 (0.70)	44.2 (1.74)	38.1 (1.50)	22.9 (0.90)	9.7 (0.38)
	F-6N- 3/8" Female NPT												
	F-8N- 1/2" Female NPT												
	D-8T- 1/2" DK-Lok												
	M-8N- 1/2" Male NPT												
	D-12T- 3/4" DK-Lok												
	D-12M- 12 mm DK-Lok												
	D-16M- 16 mm DK-Lok												
	D-8M- 8 mm DK-Lok												
	D-10M- 10 mm DK-Lok												

All dimensions shown are for reference only and are subject to change. Dimensions with DK-Lok nuts are in finger-tight position.

3-way Diverter Ball Valves

Pressure-Temperature Curve

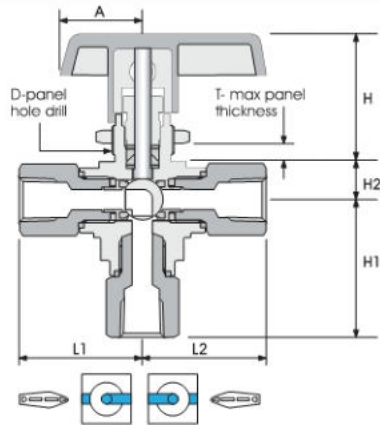

VH86 3-way Ball Valve is designed to switch media through the bottom port and direct it to out of two outlet ports.

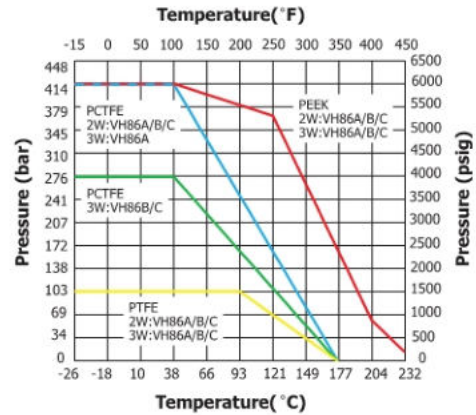

Legend : 2W:2-Way VH86 ball valves
3W:3-Way VH86 ball valves

Technical Data

Valve Series	Sealing Materials			Pressure Rating @ -27 to 37 °C (-20 to 100 °F)	Temperature Rating °C (°F)
	Seat	Stem Packing	Retainer / End Seal		
VH86A-3B	PCTFE	PTFE	PTFE	6,000 psig (413 bar)	-30 to 180 °C (-22 to 356 °F)
	PEEK	PTFE	PTFE	6,000 psig (413 bar)	-54 to 230 °C (-65 to 446 °F)
	PTFE	PTFE	PTFE	1,500 psig (103 bar)	-30 to 176 °C (-22 to 349 °F)
VH86B-3B VH86C-3B	PCTFE	PTFE	PTFE	4,000 psig (276 bar)	-50 to 180 °C (-58 to 356 °F)
	PEEK	PTFE	PTFE	6,000 psig (413 bar)	-54 to 230 °C (-65 to 446 °F)
	PTFE	PTFE	PTFE	1,500 psig (103 bar)	-30 to 176 °C (-22 to 349 °F)

Ordering Information and Dimensions

Basic Ordering Number	End Connections	Orifice		Cv	Dimensions mm (in.)								
		mm	Inch		L1	L2	H1	H2	H	A	D	T	
		VH86A-3B-	D-1T-		1/16" DK-Lok	1.3	0.052	0.06	33.0 (1.30)	33.0 (1.30)	35.3 (1.39)	8.4 (0.33)	24.8 (0.98)
D-2T-	1/8" DK-Lok		2.4	0.093	0.21	34.5 (1.36)	34.5 (1.36)	36.8 (1.45)					
F-2N-	1/8" Female NPT		4.2	0.165	0.63	27.2 (1.07)	27.2 (1.07)	29.2 (1.15)					
M-2N-	1/8" Male NPT		4.2	0.165	0.59	30.0 (1.18)	30.0 (1.18)	32.0 (1.26)					
D-4T-	1/4" DK-Lok		4.2	0.165	0.63	37.6 (1.48)	37.6 (1.48)	39.6 (1.56)					
M-4N-	1/4" Male NPT		4.2	0.165	0.59	34.3 (1.35)	34.3 (1.35)	36.3 (1.43)					
VH86B-3B-	D-2T-	1/8" DK-Lok	2.4	0.093	0.21	41.9 (1.65)	41.9 (1.65)	45.5 (1.79)	11.9 (0.47)	38.9 (1.53)	25.4 (1.00)	19.6 (0.77)	6.4 (0.25)
	D-4T-	1/4" DK-Lok	4.7	0.187	0.70	44.2 (1.74)	44.2 (1.74)	47.8 (1.88)					
	F-4N-	1/4" Female NPT	5.0	0.196	0.87	38.4 (1.51)	38.4 (1.51)	41.9 (1.65)					
	DDM-T4N-*	1/4" DK-Lok, 1/4" Male NPT	4.7	0.187	0.70	44.2 (1.74)	44.2 (1.74)	47.8 (1.88)					
	M-4N-	1/4" Male NPT	5.0	0.196	0.87	41.1 (1.62)	41.1 (1.62)	44.7 (1.76)					
	D-6T-	3/8" DK-Lok				45.7 (1.8)	45.7 (1.8)	49.3 (1.94)					
VH86C-3B-	M-6N-	3/8" Male NPT	4.7	0.187	0.70	41.1 (1.62)	41.1 (1.62)	44.7 (1.76)	17.8 (0.70)	44.2 (1.74)	38.1 (1.50)	22.9 (0.90)	9.7 (0.38)
	D-6M-	6 mm DK-Lok				44.5 (1.75)	44.5 (1.75)	47.8 (1.88)					
	D-8M-	8 mm DK-Lok	5.0	0.196	0.87	45.2 (1.78)	45.2 (1.78)	48.5 (1.91)					
	D-10M-	10 mm DK-Lok				46.0 (1.81)	46.0 (1.81)	49.5 (1.95)					
	F-6N-	3/8" Female NPT	10.3	0.406	3.62	49.5 (1.95)	49.5 (1.95)	58.2 (2.29)					
	F-8N-	1/2" Female NPT				54.6 (2.15)	54.6 (2.15)	63.2 (2.49)					
D-8T-	1/2" DK-Lok	59.4 (2.34)				59.4 (2.34)	68.1 (2.68)						
DDF-8T8F-*	1/2" DK-Lok, 1/2" Female NPT						63.2 (2.49)						
M-8N-	1/2" Male NPT	56.4 (2.22)				56.4 (2.22)	65.8 (2.59)						
D-12T-	3/4" DK-Lok	9.5				0.375	3.46	68.1 (2.68)	68.1 (2.68)	67.8 (2.67)			
D-12M-	12 mm DK-Lok		58.9 (2.32)	58.9 (2.32)	67.8 (2.67)								
D-16M-	16 mm DK-Lok	10.3	0.406	3.62	59.2 (2.34)	59.2 (2.34)	65.5 (2.58)						

* All dimensions shown are for reference only and are subject to change.
* Dimensions with DK-Lok nuts are in finger-tight position.

* VH86 3-way ball valves are described by first the outlet ports (1) and (2) and next the bottom inlet port (3).



P series Rack and Pinion Pneumatic Actuator

A Type

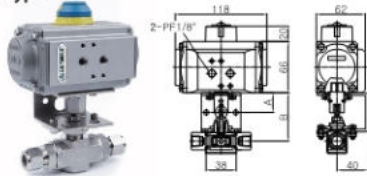

Model shown: VH86B/C series
A dimension
 VH86B: 25.00
 VH86C: 27.50
B dimension (Unit: mm)
 VH86B: 62.00
 VH86C: 90.90

B Type

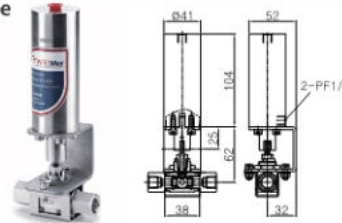

Model shown :VH86B series

Table 1. Actuator Material of Construction

Parts	Standard Material
Body	Extruded Aluminum Alloy with external & internal corrosion protection.
Piston (Rack)	Die Cast Aluminum Alloy Anodized.
Drive Shaft (Pinion)	Steel Alloy Nickel Plated.
Spring	Spring Alloy Steel Nickel Plated. (min. 5, max. 12 spring)
End Cap	Die Cast Aluminum Alloy Polyester Coated.
O-Ring	NBR is standard. Optional FKM and Silicon.

- Body : Stainless Steel structure
 Standard – Stainless Steel 304L
 Option – Stainless Steel 316L

Technical Information

Actuator operating temperature (°C)

- Standard : NBR O-Ring - 20 to 80.
- Low Temperature : Silicon O-Ring -40 to 80 (Designator : LT).
- High Temperature : FKM O-Ring -15 to 150 (Designator : HT).
- Air-pressure : Min. 2.5 bar, Max. 8 bar.
- Air supply end connection : Female G 1/8 inch (ISO 228-1).
- Position indicator is standard.

Actuator operating temperature (°C)

- 10 to 60
- For TWISTMax actuators wider temperature range please refer to DK-LOK representative
- Air-pressure: Min. 4 bar, Max. 8 bar.
- Air supply end connection: Female G 1/8 inch (ISO 228-1).
- Position indicator is optional.

Table 2. Single Return 90 Deg. Actuator

Actuator Type	Valve series	Ordering Number		Dimensions L x H x W unit: mm	Weight Kg	Moment Values P=6 bar Nm	Air Consumption Liter	Mounting Bracket Ordering Number	Actuator Operating Temperature Options
		Normal Close	Normal Open						
A Type	VH86A	PCS1	POS1	118x86x62	0.9	3.5	0.1	VH86A-SMB	Nil : Standard Temp. LT : Low Temp. HT : High Temp.
	VH86B								
	VH86C								
B Type	VH86A/B/C	TCS1	TOS1	ø 41x104	0.5	7.5	0.04	VH86A/B/C-TMB	-

Mount bracket : Field assembly kit includes mount bracket, valve to actuator, bracket bolts and assembly manual.

Table 3. Double Return 90 Deg. Actuator

Actuator Type	Valve series	Ordering Number	L x H x W unit: mm	Weight Unit: Kg	Moment Values P=6 bar Nm	Air Consumption Liter	Mounting Bracket Ordering Number	Actuator Operating Temperature Options
	VH86B							
	VH86C							
B Type	VH86A/B/C	TD1	ø 41x104	0.4	20.5	0.1	VH86A/B/C-TMB	-

How to Order

Select applicable valve pattern, seat options, pneumatic actuator, and the actuator temperature option from designator listed below.

VH86B-D-6T- -PK	-SG	-PCS1	-HT	-S
VH86C-D-12T				-S
Seat Material	Sour Gas	Factory Assembled Actuator	Actuator Temperature Options	Valve Body Material
Nil : PCTFE PK : PEEK PE : PTFE	SG : Sour Gas	For single return, see Table 2. For double return, see Table 3.	Nil : Standard Temp. LT : Low Temp. HT : High Temp.	S : S316

Safe Valve Selection

The selection of a valve for any application or system design must be considered to ensure safe performance. Valve function, valve rating, material compatibility, proper installation, operation and maintenance remain the sole responsibility of the system designer and the user. DK-Lok accepts no liability for any improper selection, installation, operation or maintenance.

 Fittings & Valves www.dklok.com	 Mailing Address 7, Golden root-ro 129beon-gil, Juchon-myeon, Gimhae-si, Gyeongsangnam-do, South Korea 621-842	DK-Lok contact information	For International customers
		Tel. (82) 55-338-0114 Fax. (82) 55-901-0143 E-mail : sales@dklok.com	Tel. (82) 55-338-0031/2 Fax. (82) 55-901-0142 E-mail : dklok@dklok.com